

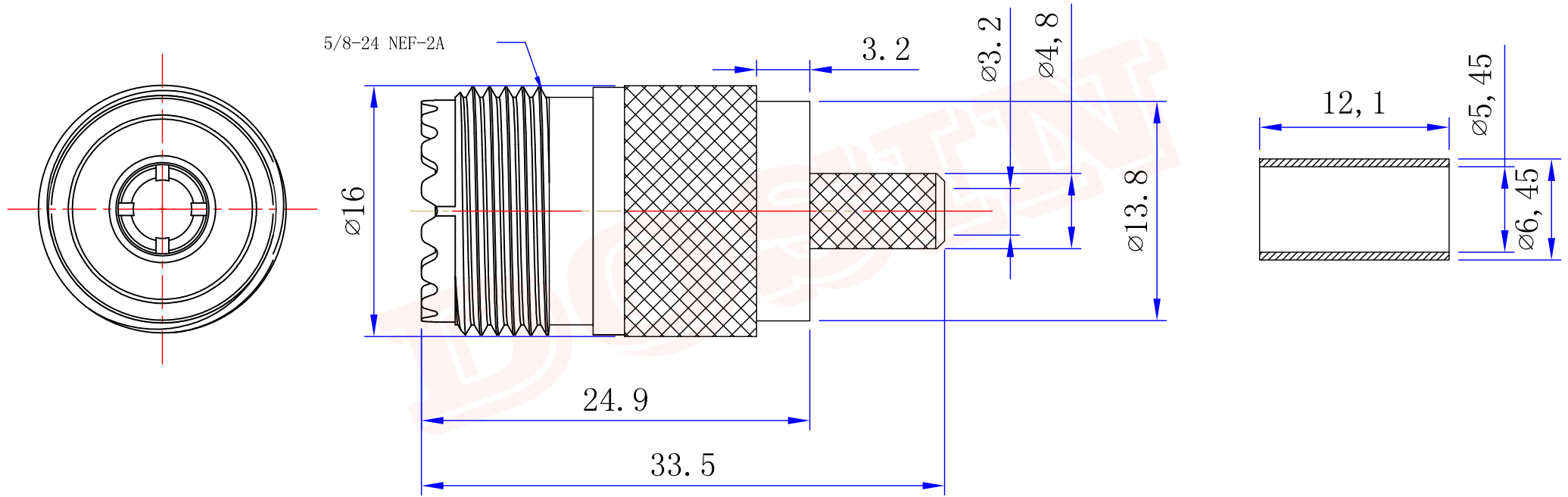

Product NO.		DOSIN-847-0131		
REV	DESCRIPTION	DWN	DATE	APPROVEN
A	First issue	Gavin	2018/06/05	John kine
B				

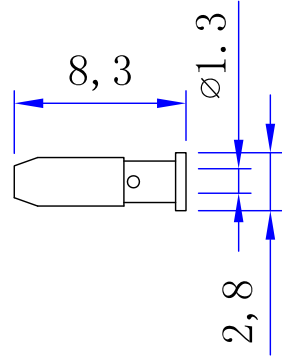

NO	DESCRIPTION	MATERIAL	FINISH	QTY
3	PIN	BRASS	SN	1
2	DIELECTRIC	TEFLON	NONE	1
1	BODY	BRASS	Black chromium	1

Tolerance	X. $\pm 0.1$ X.X $\pm 0.15$ X.XX $\pm 0.20$ Angular $\pm 5^\circ$
View	
UNIT	MM
SCALE	1:1

**DOSIN** -RF CONNECTOR  
**Dosin Industrial(H.K)Co.Ltd**  
 东莞市德索五金电子制品有限公司  
 Dosin Hardware Electronics Co.,Ltd

dosin2005@dosin-china.com  
 Web: http://www.china-guan.com  
 TEL: (0086) 769-81153906  
 FAX: (0086) 769-81875836

Name: **UHF-SL16-C-KF5**

SIZE	Product NO.	DOSIN-847-0131	REV	A
DateTime	CAD FILE	D/company drawings/BD	SHEET: 1 OF 1	
2018/06/05				