

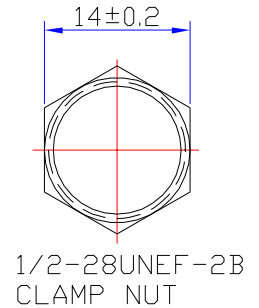

Product NO.		DOSIN-801-1582		
REV	DESCRIPTION	DWN	DATE	APPROVEN
A	First issue	Gavin	2022/03/11	John kine

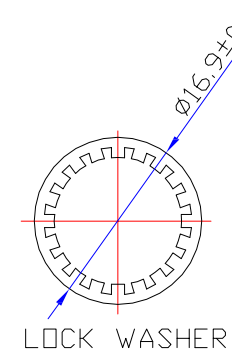
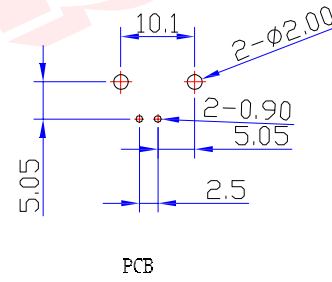
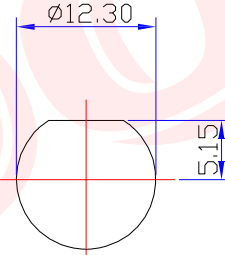
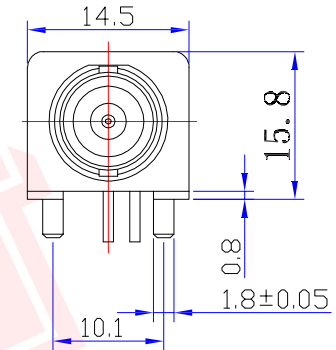
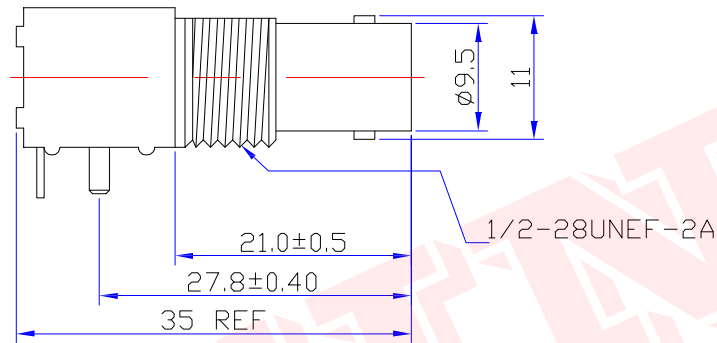
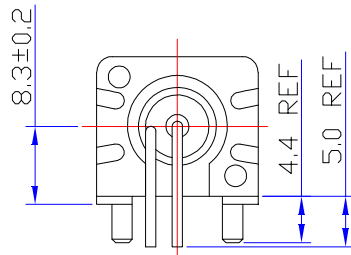

Specifications

Impedance:75 Ohms
 Frequency Range:DC~3G
 VSWR:1.3MAX
 Working Voltage:500V rms @ sea level
 Insulation Resistance:5000 Ohms min
 Temperature Range:-55°C TO +155°C
 Relative Temperature:≤95%(40° C±2° C)
 Drawings products are in line with ROHS standards

1	Body	Zicc	Ni:80-120u"	1
2	Center Contact	Brass	AU:1U"	1
3	Lead	Iron	AU:1U"	1
4	Fixed footrest	Iron	Ni:80-120u"	1
5	Insulator	POM	White	1
6	Fixed mouunt	PBT	White	1
7	Washer	Brass	Ni:80-120u"	1
8	Hex Nut	Brass	Ni:80-120u"	1
NO	DESCRIPTION	MATERIAL	FINISH	QTY

Tolerance	0.5 - 8mm ± 0.20mm 8 - 30mm ± 0.25mm 30 -120mm ± 0.30mm
View	
UNIT	MM
SCALE	1:1

Dosin Industrial (H.K) Co.Ltd 东莞市德索五金电子制品有限公司 Dosin Hardware Electronics Co.,Ltd		dosin2005@dosin-china.com Web:http://www.china-guan.com TEL: (0086) 769-81153906 FAX: (0086) 769-81875836	
Name: 75 Ohms BNC White Plastic Connector(15.8mm)			
SIZE A	Product NO.	DOSIN-801-1582	REV A
DateTime 2022/03/11		CAD FILE D/company drawings/BD	SHEET: 1 OF 1